

Vertigo



All pictures are for illustration purposes. Colours, product dimension, specification as well as designs are subject to change without prior notice. Colours shown here may differ from the actual product.



MALAYSIA
Bristol Technologies Sdn Bhd
Lot 5178 Balakong Jaya Light Industri,
43300 Seri Kembangan, Selangor, Malaysia.
Tel: +603 8962 3233
Fax: +603 8962 6322
Email: export@bristol.com.my
Web: www.bristol.com.my
www.facebook.com/bristolfurniture



Vertigo is designed to work in any work spaces and it is flexible enough for the users to adapt the work surface height to their needs instantly. Vertigo can be used as a freestanding or panel based work environment and with its sit-to-stand concept, it can be used seated one minute, then raised to create a standing meeting place or to simply change posture the next.



ysyong
Design Team
Albott Design Studio



jong pai suang



mahdieh



Vertigo

Sit to Stand.

Vertigo.
From sit to stand.



User Enhanced Safety Feature (anti-collision)

The lifting column is equipped with an anti-collision technology (PIEZO) to halt and reverse the table top for any detected obstruction underneath or above the work surface.



Vertigo can be adjusted single-handedly to any height on the fly, easily going from seated to standing, and back again. Simply press the up or down button on the control panel located at the bottom edge of the worksurface to raise or lower the height of the worksurface. The control panel has a LED display for height read-out and pre memory to store favourite positions.



Vertigo (Motorised)

Worksurface
Available in 25mm Melamine Face Chipboard (MFC)
or High Pressure Laminate (HPL)

Power outlet
Can be installed on the worksurface
or cable tray beneath the worksurface

Control box
Fully hidden control box

Horizontal Beam
Metal rectangular beam 25 x 50
with hidden transmission shaft.

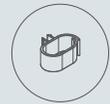

Wire Clip
Translucent plastic clips on aluminum
extruded rail for routing wire from floor to
worksurface.

Lifting Column
Made of aluminum extrusion for
height synchronization. Columns
are precisely balanced to
minimize surface vibrations.



Leveling glides
Made from nylon.
Adjustable range of 10mm to install
unit on uneven floors.

Brace Bar
Aluminum extrusion bar for
stability purpose.

Brace Bar Connector
Aluminum die cast connector
to connect brace bar to
lifting column.

Base/Leg
Aluminum die cast leg
supports a maximum
distributed weight of 120kg.

Vertigo. Meeting.

Standing meeting tables have become essential in larger conferences and meetings. Studies show that stand up meetings are shorter and more productive. One study found that productivity increased by 20% and meeting times were reduced by over 30%.

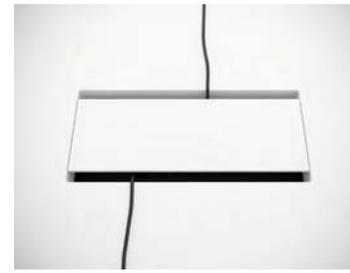

The dual hinge flap cover allows user to access the power and data points from both side of the table.



A remote control that allows user to adjust the height of the table from a distance.

Vertigo (Motorised)

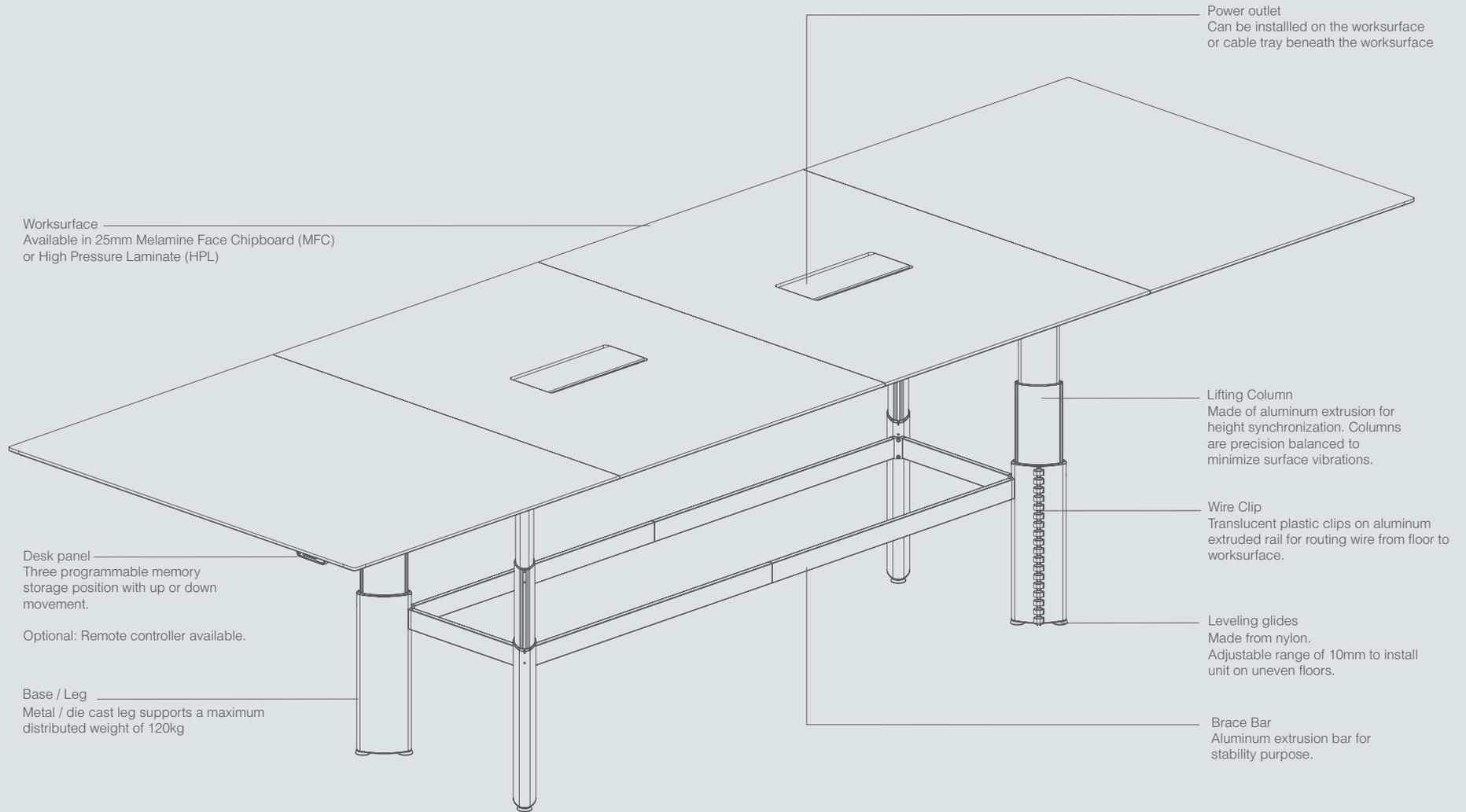

Vertigo.
Handcrank.



"Studies show that Sit-to-Stand table helps improve metabolic rate and burn more fat."



Vertigo.
Handcrank.



A retractable handle for manual cranking of the table top height.

With its independent leg system, the workstation can be configured to either linear or 120 degree workspace. This allows Vertigo workspaces to maximize space and create a cohesive workspace.

Vertigo (Handcrank)

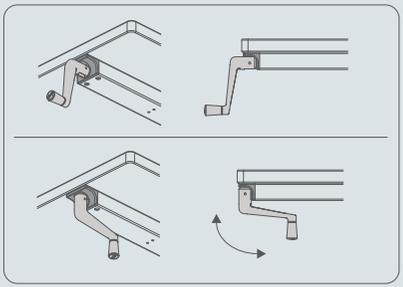
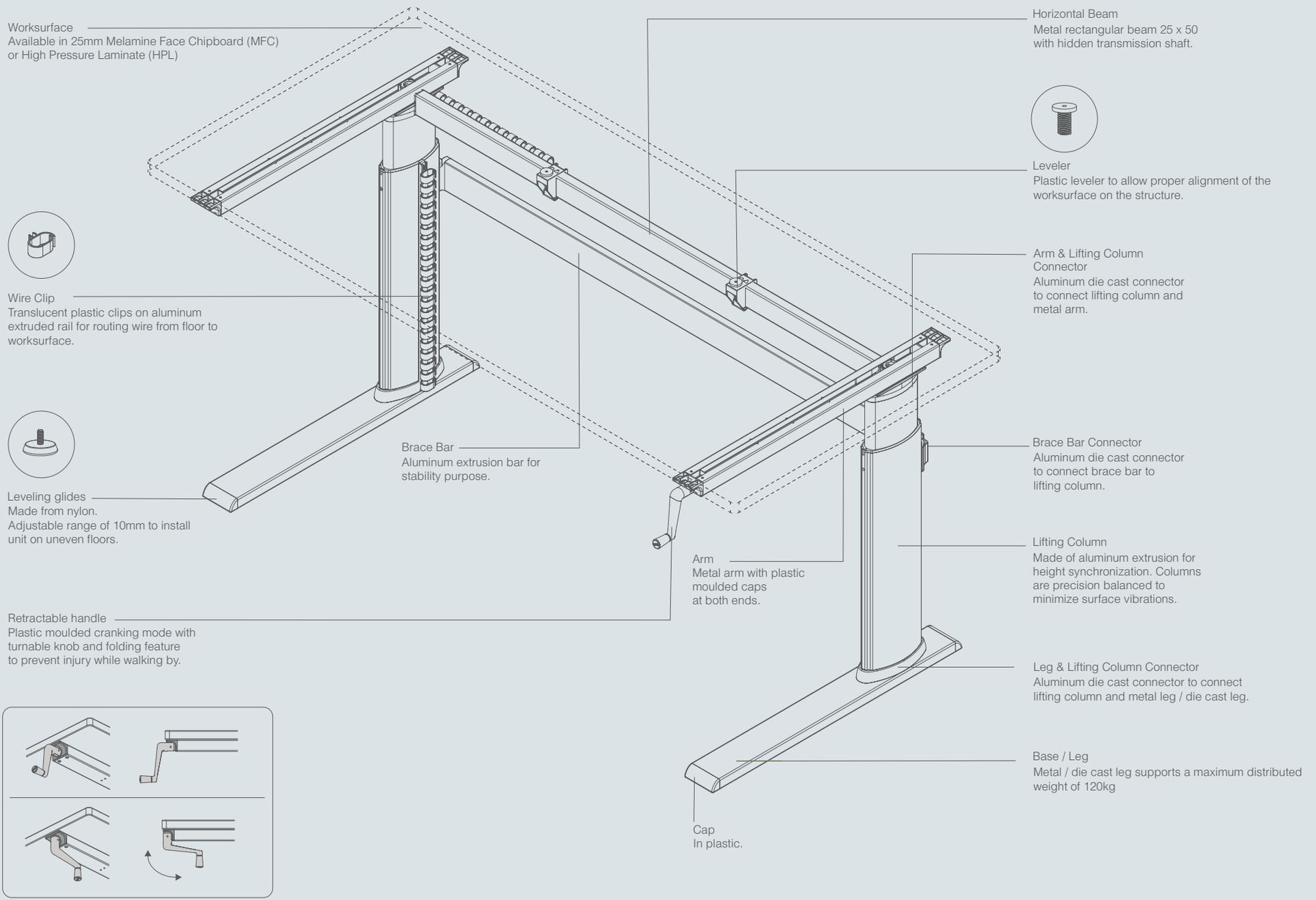

Vertigo
Specifications



Lifting weight
The lifting mechanism can lift up to 120kg of table top weight.



Height adjustment

Motorized: Table top's height can be adjusted from 680 - 1200mm.
Handcrank Sheet Metal Leg: Table top's height can be adjusted from 680 - 1050mm.
Handcrank Diecast Leg: Table top's height can be adjusted from 680 - 980mm.

Vertigo
Statement of line

Motorized Diecast Leg

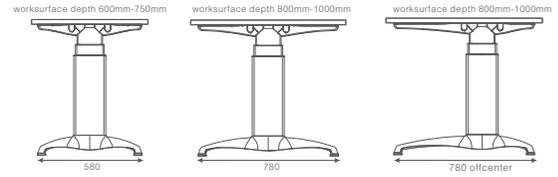

Motorized Metal Leg

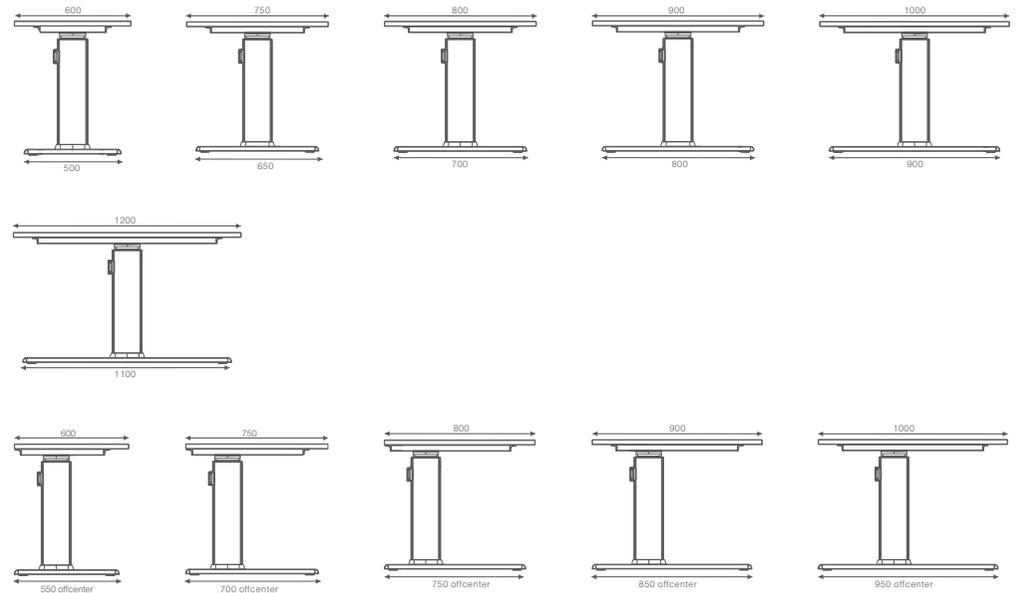

Handcrank

